

ALGE-TIMING

Speakersystem BANG CW



Manual

Important Information

General

Before using your **ALGE-TIMING** device read the complete manual carefully. It is part of the device and contains important information about installation, safety and its intended use. This manual cannot cover all conceivable applications. For further information or in case of problems that are mentioned not at all or not sufficiently detailed, please contact your **ALGE-TIMING** representative. You can find contact details on our homepage www.alge-timing.com

Safety

Apart from the information of this manual all general safety and accident prevention regulations of the legislator must be taken into account. The device must only be used by trained persons. The setting-up and installation must only be executed according to the manufacturer's data.

Never adjust the active speaker system to a very high volume. Permanent high volumes may damage your hearing! The human ear will get accustomed to high volumes which do not seem to be that high after some time. Therefore, do not further increase a high volume after getting used to it.

Intended Use

The device must only be used for its intended applications. Technical modifications and any misuse are prohibited because of the risks involved! **ALGE-TIMING** is not liable for damages that are caused by improper use or incorrect operation.

Power supply

The stated voltage on the type plate must correspond to voltage of the power source. Check all connections and plugs before usage. Damaged connection wires must be replaced immediately by an authorized electrician. The device must only be connected to an electric supply that has been installed by an electrician according to IEC 60364-1. Never touch the mains plug with wet hands! Never touch live parts!

Cleaning

Please clean the outside of the device only with a smooth cloth. Detergents can cause damage. Never submerge in water, never open or clean with wet cloth. The cleaning must not be carried out by hose or high-pressure (risk of short circuits or other damage).

Liability Limitations

All technical information, data and information for installation and operation correspond to the latest status at time of printing and are made in all conscience considering our past experience and knowledge. Information, pictures and description do not entitle to base any claims. The manufacturer is not liable for damage due to failure to observe the manual, improper use, incorrect repairs, technical modifications, use of unauthorized spare parts. Translations are made in all conscience. We assume no liability for translation mistakes, even if the translation is carried out by us or on our behalf.

Disposal

If a label is placed on the device showing a crossed out dustbin on wheels (see drawing), the European directive 2002/96/EG applies for this device.

Please get informed about the applicable regulations for separate collection of electrical and electronic waste in your country and do not dispose of the old devices as household waste. Correct disposal of old equipment protects the environment and humans against negative consequences!

Copyright by **ALGE-TIMING GmbH**

All rights reserved. Any duplication, either in full or in part, requires the prior written consent of the copyright holder.



Declaration of Conformity

We hereby declare that the following product complies with the below stated standards. All components used by us are CE certified by their producer and are not modified by ALGE-TIMING GmbH.

We, **ALGE-TIMING GmbH**
Rotkreuzstrasse 39
A-6890 Lustenau

declare in sole responsibility that the electronic start device

BANG CW

complies with the following standards/normative documents and in case of intended use complies with the basic requirements of R&TTE 1999/5/EC:

Telecommunication (TC)terminal device

Applied harmonized standards...

EN 60065:2006
EN 60950-1:2006+A11:2009+A1:2010+A12:2011
EN 61000-3-2+A1+A2
EN 61000-6-4:2007
EN 61000-3-3:2013
EN 61000-6-3:2007/A1:2011/AC:2012

EN 61000-6-1:2007
EN 61000-6-2:2005
EN 55024:2010
EN 300422V1.2.2
EN 301489-1V1.8.1
EN 301489-9V1.4.1

Additional information:

The product complies with the low voltage directive 73/23/EEC and EMC directive 2004/108EG and carries the CE sign.

Lustenau, 2015-06-12

ALGE-TIMING GmbH



Albert Vetter
(CIO)

Table of Contents

1	Operating Elements and Connections.....	5
2	General.....	6
2.1	Use of BANG CW	6
2.2	Setting up	6
2.3	Audio Connections.....	7
2.3.1	Inputs.....	7
2.3.2	Output LINE OUT	7
2.3.3	Passive Speaker System.....	7
2.4	Connections for Timing.....	7
2.5	Wireless Timing Network WTN	7
2.5.1	Radio Power Output	8
2.5.2	Adjustment of Team Number	8
2.5.3	Timing Channel.....	8
2.5.4	LED for Radio (16).....	8
2.6	Accessory	9
2.6.1	Weather Protection BANG-BAG	9
2.6.2	Tripod BANG-TRI	9
2.6.3	BANG SPK	9
3	Commissioning	9
4	Operation	10
5	Power Supply	11
5.1	Mains.....	11
5.2	Rechargeable Battery	11
5.2.1	Battery Operating Time.....	11
5.2.2	Charging Battery.....	11
6	Functions.....	12
6.1	Start Unit SU2 or SU3.....	13
6.2	Speech Amplifier SV4-S or SV4/SM	13
7	Technical Specifications.....	14
7.1	Amplifier and Speaker	14
7.2	Connections for Timing.....	14
7.3	Radio Module WTN for Timing.....	14
8	Special Settings	15

1 Operating Elements and Connections

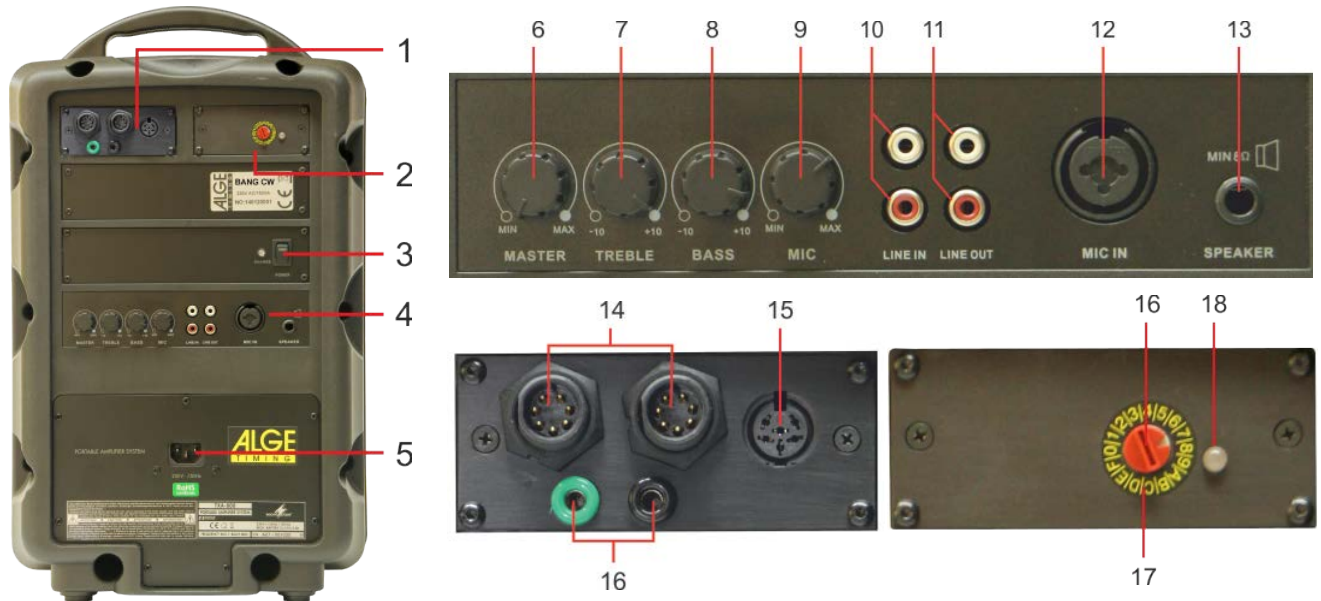

- 1..... Connections for timing
- 2..... Wireless Timing Network WTN
- 3..... On-off switch
- 4..... Amplifier controller und amplifier connections
- 5..... Mains (90 - 230 V~ / 47 – 63 Hz)
- 6..... Control MASTER for the master volume of the active speaker system
- 7..... Tone controls TREBLE for the mixed signal
- 8..... Tone controls BASS for the mixed signal
- 9..... Volume control for the microphone at the input MIC IN (11)
- 10..... Input LINE IN (phono jacks) for a stereo audio source with line output level, e. g. CD player, cassette recorder
- 11..... Output LINE OUT (phono jacks) for passing on the mixed signal, e. g. to a recorder or another active speaker system.
Note: The adjustments of the tone controls (7) affect the LINE OUT signal; the adjustment of the control MASTER (6), however, does not affect it.
- 12..... Input MIC IN (combined 6.3mm/XLR jack, bal.) for connecting a microphone).
- 13..... 6.3 mm jack SPEAKER for connecting an additional passive speaker system (minimum impedance 8Ω)
- 14..... 2 x LTW-jack to connect at the timing devices or further speakers (e.g. BANG, Start Unit SU2, Start Unit SU3, FLASH, TimeMaster)
- 15..... DIN-jack to connect starting devices (e.g. e-Start or start microphone SM8)
- 16..... Rotation Switch to adjust the WTN team
- 17..... Scale for WTN team (1 – 9 = single teams, A – F = common teams)
- 18..... LED for WTN reception

2 General

ALGE-TIMING offers two different models of the active box (speaker-amplifier system) BANG:

- BANG wired speaker system
- BANG W radio speaker system
- BANG CW..... wired speaker system with radio for false start impulses

In this manual the model **BANG CW** is described. The model BANG and BANG W has a separate manual.

2.1 Use of BANG CW

The BANG CW is a device that is used in the start area at sports events to output the start tone and false start tone. Further it is possible to make announcements (e.g. starting commands). Starting devices (e.g. StartUnit SU3 or e-START) will be connected by cable with the BANG CW. Additional it is possible to receive a false start impulse by radio (e.g. e-Start W or WTN-PB). This allows the recaller to move free in the start area without taking care of a cable.

2.2 Setting up

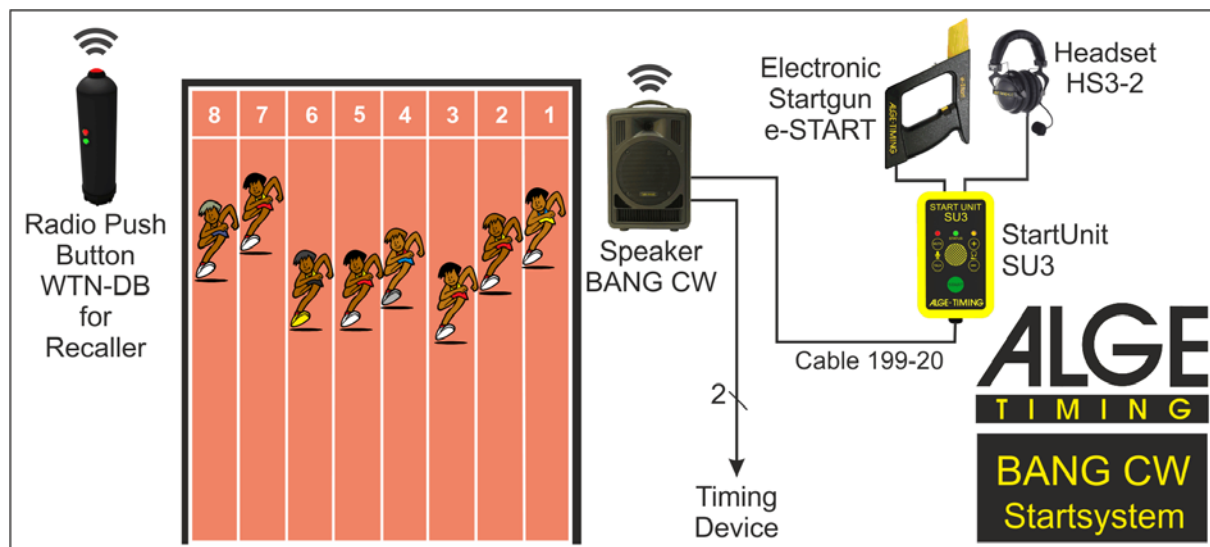

The BANG CW is suitable for indoor use only. Protect it against dripping water and splash water, high air humidity, and heat (admissible ambient temperature range 0 – 40 °C).

The BANG CW can be setup free or on the **ALGE** tripod **BANG-TRI**. When using it outdoors it must be protected against rain or snow with the rain protection **BANG-BAG**. The rain protection must remain on the BANG during operating.

This active speaker system BANG is a combination of a 2-way speaker system and an amplifier with connections for a microphone and an audio unit with line output level, e. g. CD player or cassette recorder.

The BANG CW can be integrated in a timing system in order to create a simulated start gun sound or start tone. Additionally, it can acoustically output a false start tone.

The BANG CW can be connected with a false start device (e.g. e-Start or WTN-PB) by radio. This will activate an acoustic false start tone.

The unit can either be operated from the mains or via the internal rechargeable lead gel batteries to be charged with the integrated charging part. Thus, the speaker system is ideally suited for mobile applications like sport events.

2.3 Audio Connections

2.3.1 Inputs

A microphone and a stereo unit with line output level (e. g. CD player, DVD player, cassette recorder or MD recorder) may be connected as audio sources:

- Connect the microphone either via XLR plug or 6.3 mm plug to the balanced jack MIC IN (12).
- Connect the stereo unit with line output to the phono jacks LINE IN (10).

2.3.2 Output LINE OUT

The phono jacks LINE OUT (11) allow e. g. connection of a recorder or another active speaker system for PA application. At both jacks the mixed mono signal of the speaker system is available. The control MASTER (6) for the master volume of the active speaker system does not affect the signal at the output LINE OUT; the adjustments of the tone controls TREBLE (7) and BASS (8).

Note: The BANG CW is not provided with a volume control for the unit at the input LINE IN (10); i.e. the signal of the unit is always fed to the output LINE OUT at its input volume.

2.3.3 Passive Speaker System

If a speaker system (without amplifier) is additionally required for PA applications, it may be connected to the jack SPEAKER (13). The minimum impedance of the speaker system must be 8Ω. ALGE-TIMING offers the passive speakers BANG SPK as accessory for the BANG. You can connect on one BANG up to eight BANG SPK.

2.4 Connections for Timing

The BANG CW is connected with the timing system.

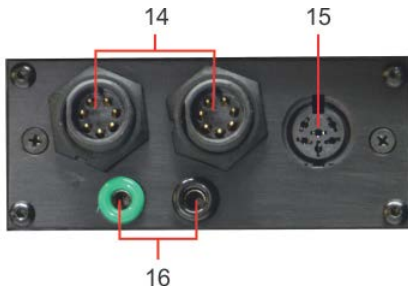

- 14.....2 x LTW-jack to connect at the timing devices or further speakers (e.g. BANG, Start Unit SU2, Start Unit SU3, FLASH, TimeMaster)
- 15.....DIN-jack to connect starting devices (e.g. e-Start or start microphone SM8)
- 16.....Banana jacks (green and black) for the start line connection with the timing device (closing contact, open collector)

2.5 Wireless Timing Network WTN

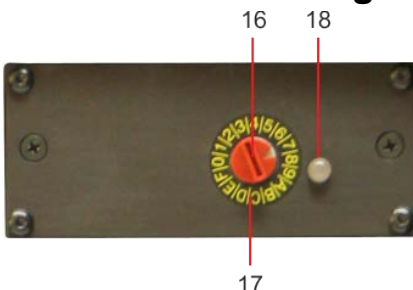

- 17.....Rotation Switch to adjust the WTN team
- 18.....Scale for WTN team (1 – 9 = single teams, A – F = common teams)
- 19.....LED for WTN reception

The ALGE Wireless Timing Network WTN is a compact radio system for timing and is equipped with the most updated technology. The BANG CW has a WTN-radio module built in and is fully compatible with the WTN

A radio network consists of two or more devices of the WTN series. In such a network every device communicates with every other device inside the network.

The network is designed in such a way that you can transmit data to a display board (e.g. D-LINE), serial RS232 data (e.g. PC) and timing impulses at the same time.

When designing the Wireless Timing Network the **ALGE** development team concentrated on features that make **ALGE** devices unique, but also on features that stand for **ALGE** products: easy operation, highest reliability, rugged casing. Up-to-date technology, integrated in a solid case, results in exceptional features.

Attention: Before using the device make sure that you are allowed to operate it in your country. The radio power output must be adjusted so that it is legal to use it in the country you operate it in.

The quality of the network status for a WTN system is crucial. Before you start to use the WTN network check the connection quality of every WTN device used in the system. In order to work in a stable network every WTN should show at least a good connection quality (the radio indication of the BANG W should blink green).

2.5.1 Radio Power Output

The radio power output is adjusted to 10 mW. It can be adjusted between 10 mW and 100 mW. It is not possible to change the power output directly in the BANG W. If you adjust the power output in another device of the network (e.g. Wireless Timing Network WTN), then it sets all devices in this network to the newly adjusted power output (as well the BANG W).

2.5.2 Adjustment of Team Number

This function is to select the team number of a WTN system. You can select between 15 team numbers. There are 9 single teams (S) and 6 common teams (A). The factory setting is 1 (single mode).

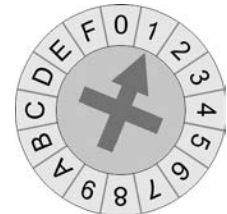

Separate Teams <S> = SINGLE

Used for completely independent networks. If you operate two networks next to each other both networks work in this mode on different frequencies and do not communicate amongst each other.

Single = rotation switch 1, 2, 3, 4, 5, 6, 7, 8 and 9

Joint Teams <A> = ALL

Used for networks that work independently next to each other. If different A teams with the same radio channel are operated, the other A teams can be used for data transmission. The data of the other team however is not used (e.g. for two show jumping grounds that are next to each other).

2.5.3 Timing Channel

When the BANG W receives a timing impulse from channel C0 (start channel) by WTN it outputs an acoustic start signal. If it receives a further timing impulse from channel C0 within 5 seconds, it starts an acoustic false start tone (several tones in a short period of time).

Furthermore, the BANG W receives other timing impulses (C1 to C4) and passes them on to other WTN devices.

2.5.4 LED for Radio (16)

The LED for the radio shows the communication status with other devices in the same network (device with the best reception).

LED status	Function
off	radio off or on network
red blinking	very bad network reception
orange blinking	bad network reception
green blinking	good network reception

2.6 Accessory

ALGE-TIMING offers the following accessory for the BANG:

2.6.1 Weather Protection BANG-BAG

The BANG CW is made for indoor use. For outdoor use of the BANG CW when it rains or snows the BANG needs a protection.

2.6.2 Tripod BANG-TRI

The BANG can be mounted on a tripod, when it should not be on the floor.

2.6.3 BANG SPK

The passive speaker BANG SPK can be connected at the BANG (it is possible to connect a maximum of eight BANG SPK). It consists of a passive horn speaker with an output line of about 10 W. It has a fixed cable of 12 m (connection at BANG or BANG SPK and a speaker jack (RCA) to connect additional BANG SPK).

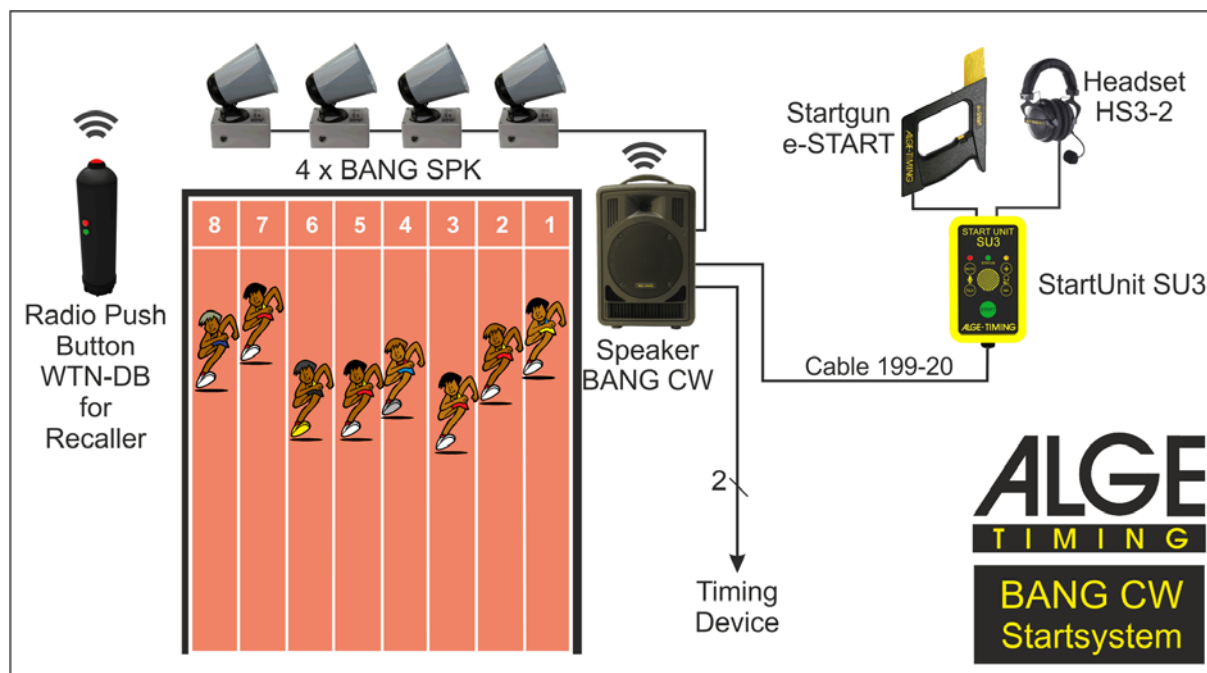

3 Commissioning

Prior to switching on, turn back the control MASTER (6) for the master volume to MIN first, and then switch on the speaker system with the switch POWER (3). The switch lights up during operation. If it starts flashing during rechargeable battery operation, the batteries are almost discharged and should be recharged.

To prevent damage to the rechargeable batteries by deep discharge during battery operation, a discharge protection automatically switches off the unit at the right time. However, due to self-discharge of the batteries, a deep discharge may also occur when the unit is not operated for a longer period of time. Therefore, always observe the notes in the chapter 5. Power Supply.

The BANG CW can be integrated with different devices from ALGE-TIMING as a start system:

Start Devices (cable connection):

- Electronic Startgun e-Start
- Start Unit SU2
- Start Unit SU3
- Start microphone SM8 with speech amplifier SV4/SM and headset HS3-2
- Push Button 023-02 or 023-10
- Photocell PR1a

False Start Devices (radio connection):

- Electronic Startgun e-Start W
- Radio Push Button WTN-PB

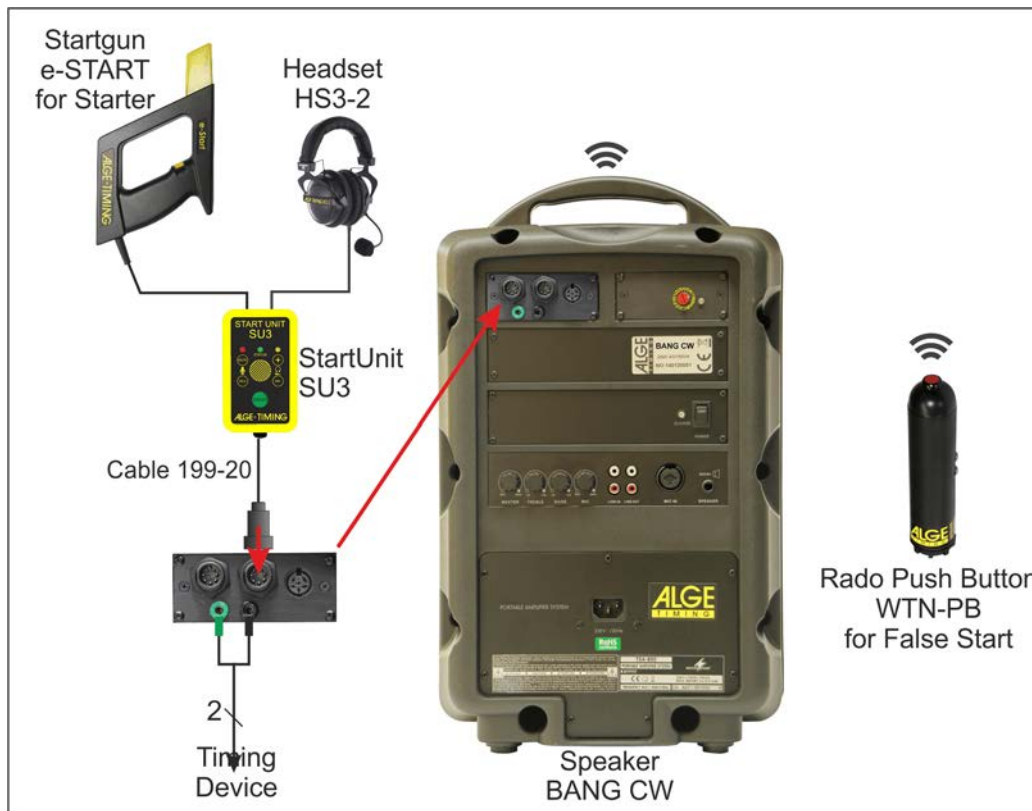

4 Operation

- Advance the control MASTER (6) for the master volume to such an extent that the subsequent adjustments can be heard well via the speakers.
- Switch on the desired signal sources and mix their signals with the corresponding volume controls or fade them in and out as required (always completely turn back the controls of the signal sources not used):
 - for the receiving unit/units (1): on-off switch and volume control (20)
 - 4.1 Multifrequency Receiving Unit for Headset micro BANG-HS
 - for the microphone at the input MIC IN (12): volume control MIC (9)

The input LINE IN (10) is not provided with an individual volume control; the volume of the signal source connected to this input can only be adjusted via the control MASTER (6) for the master volume.
- With the controls BASS (8) and TREBLE (7) optimize the sound of the mixed signal.
- With the control MASTER (6), adjust the final level for the master volume of the active speaker system, and then readjust the sound adjustments, if required.
- For the false start device (WTN-PB or e-Start W) and BANG CW you must adjust the same radio team (switch 16). The false start device must be set on channel C1.
- After operation, set the switch POWER (3) to the “off” position.

5 Power Supply

The BANG CW can be use connected to the mains or running on the internal rechargeable batteries.

5.1 Mains

To operate the active speaker system via a mains socket and/or to recharge the internal lead gel batteries, connect the mains cable provided to the mains jack (5) and to a mains socket (90 - 230 V~ / 47 – 63 Hz / 150 VA).

Mains: (90 - 230 V~ / 47 – 63 Hz / 150 VA)

5.2 Rechargeable Battery

The BANG CW has two built-in lead gel batteries (each 12 V /3 Ah) for a mains independent use.

5.2.1 Battery Operating Time

The running time of the BANG using the internal batteries depends on the volume and the duration of active use (volume output).

Operating Time: about 3 to 4 hours at normal use

5.2.2 Charging Battery

When the active speaker system is connected to the mains, the automatic charging for the rechargeable batteries is always active. The LED CHARGE lights up:

Red: the batteries are being charged

Green: the batteries have been fully charged

For charging, it is not be necessary to switch on the speaker system with the POWER switch (5); however, it can be operated as usual during the charging process.

The charge control circuit prevents overcharge of the batteries; it is recommended, however, to disconnect the mains plug from the socket after charging if the unit is not used for a longer period of time. Always fully recharge the batteries prior to initial operation and after longer storage. If the POWER switch starts flashing during battery operation, the batteries are almost discharged and should be recharged as soon as possible.

IMPORTANT:

The rechargeable batteries of the BANG CW might be exhaustively discharged and as a result of this can be damaged. A deep discharge is possible in case the battery is either not charged at all for a very long time or if the BANG CW is constantly connected to the net supply.

We therefore recommend charging the rechargeable battery completely (12 hrs.) at least once a month in order to prevent such damage. For this, a timer clock might be of assistance that automatically turns on the net supply for the recommended period of time. The timer clock is especially helpful when the device is not used for longer periods (summer/winter break).

6 Functions

If you receive a start impulse at the BANG from a device that is connected to one of the two identical LTW-jacks (14) or to the DIN jack (15) you get a start sound output.

The start sound can be adjusted from the producer (**ALGE-TIMING**) as „gun sound“ or „horn sound“. The start sound cannot be adjusted by the operator (the BANG CW needs a different software).

The BANG CW outputs a start impulse to trigger a timing device (closing contact) via the green and black banana socket (16).

If the BANG CW receives another start impulse within 5 seconds of the first start impulse it outputs a false start sound (several honks within a short time).

Receives the BANG CW a radio impulse e.g. from WTN-PB or e-Start W with the timing channel 1, than it will output an acoustic false start signal.

Attention:

All devices of the WTN series (e.g. BANG W, e-Start W, WTN-PB, WTN) must be set on the same team!

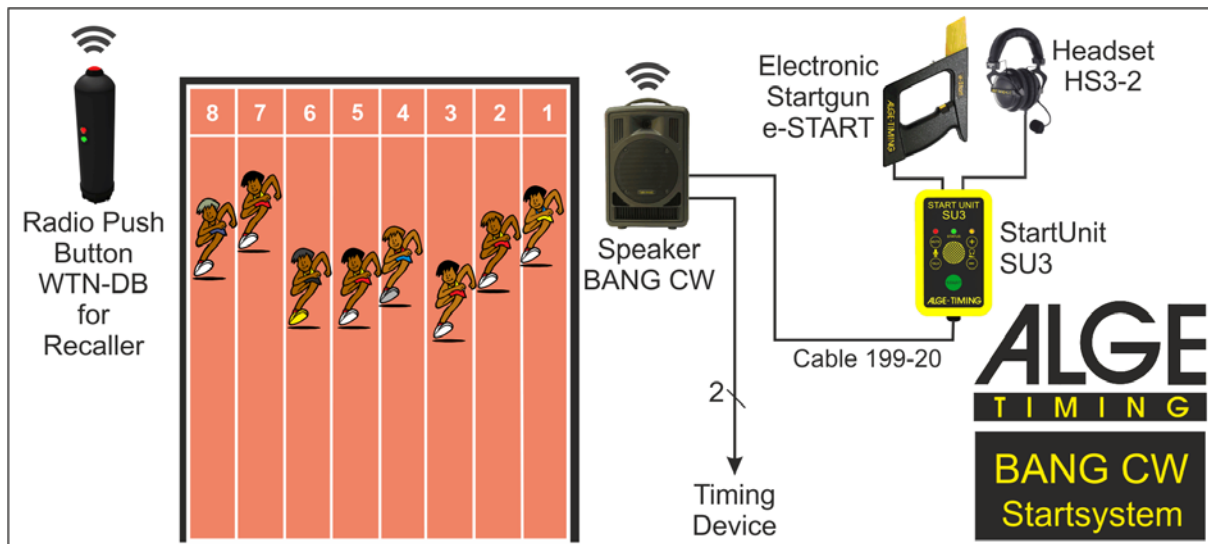

6.1 Start Unit SU2 or SU3

The Start Unit SU2 or SU3 can be connected at one of the two LTW jacks (14) with cable 199-xx. With the built-in microphone of the start unit you can give oral commands to the athletes through the BANG. Further, you can connect a headset to communicate with the timing operator.

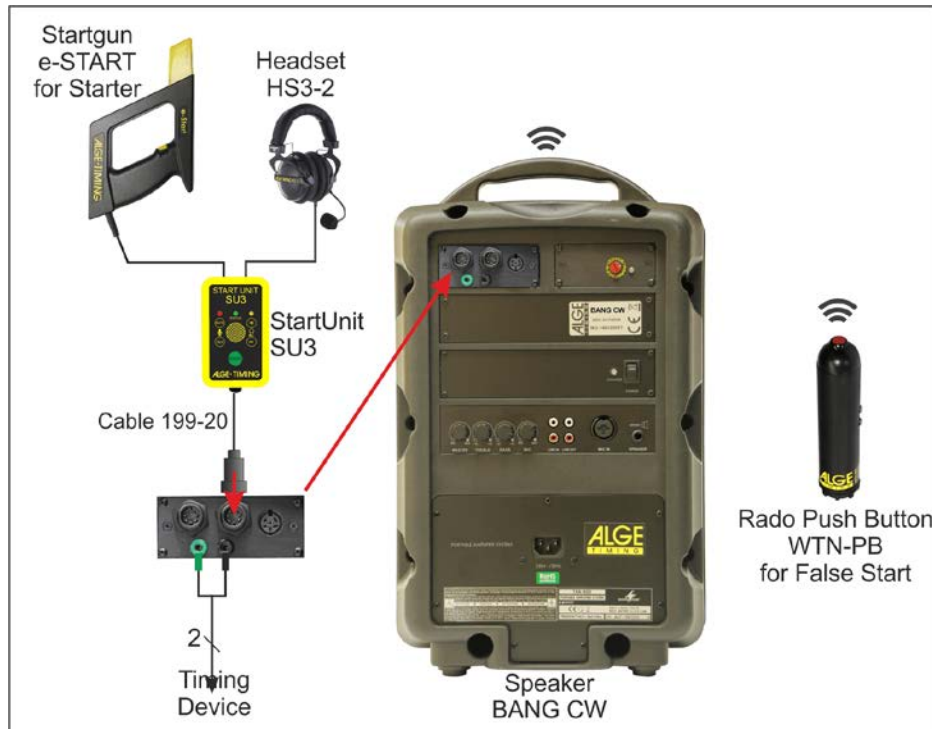

6.2 Speech Amplifier SV4-S or SV4/SM

You can connect a speech amplifier with headset at the banana socket (16) to communicate with the timing operator. Connect a two wire cable parallel at the banana socket to the timing device (start impulse).

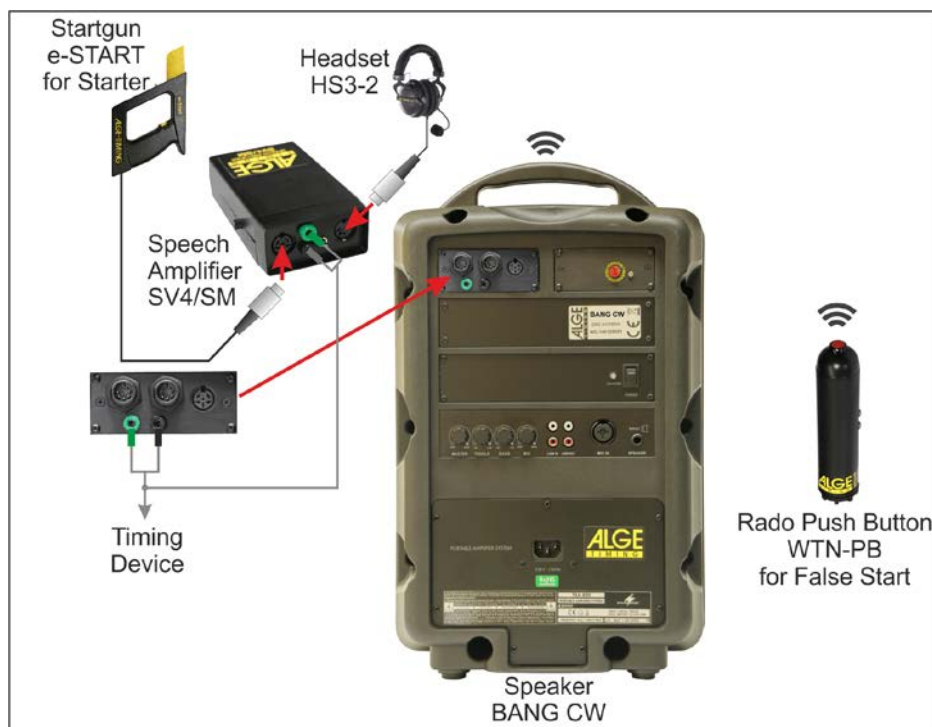

7 Technical Specifications

7.1 Amplifier and Speaker

<i>Amplifier Power:</i>	80WMAX/50WRMS
<i>Frequency Range:</i>	70 – 16 000 Hz
<i>Speaker System:</i>	20 cm (8") bass speaker and 2.5 cm (1") tweeter
<i>Input MIC IN</i>	Sensitivity: 6 mV Connection: XLR/6,3-mm-Klinke, sym.
<i>Input LINE IN</i>	Sensitivity: 800mV Connection: phono jack
<i>Output LINE OUT</i>	Level: 1 V Connection: phono jack
<i>Output SPEAKER:</i>	6.3 mm jack for a passive speaker system (minimum impedance 8Ω)
<i>Tone Controls:</i>	Treble: ±15 dB/100 Hz Bass: ±10 dB/10 kHz
<i>Ambient Temperature:</i>	0 to 40°C (32 to 104 F)
<i>Power Supply:</i>	via the mains voltage (230 V~/50Hz/150 VA) or the internal rechargeable lead gel batteries (2 × 12 V /3 Ah)
<i>Operating Time:</i>	with internal battery about four hours
<i>Dimensions:</i>	300 × 470 × 230 mm (W × H × D)
<i>Weight:</i>	ca. 11.2 kg



7.2 Connections for Timing

<i>2 x LTW jack:</i>	Connection with start devices or further speakers e.g. BANG, SU2, SU3, FLASH
<i>1 x DIN jack:</i>	Connection with start devices e.g. e-Start or start microphone SM8
<i>1 x Banana Socket (green – black):</i>	Start output signal, normally closed contact, open collector)
<i>DIN jack:</i>	1timing channel C0 (start input) 2status 3ground 4power supply output (+10 VDC _{out}) 5empty 6empty

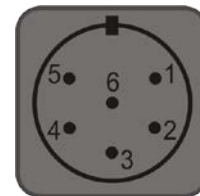

7.3 Radio Module WTN for Timing

<i>Frequency:</i>	2.4 GHz band (16 adjustable frequencies)
<i>Power Output:</i>	10 mW or 10 to 100 mW (adjustable)
<i>Timing Channels:</i>	1 timing channel C0 (start)
<i>Maximum Distance:</i>	about 300 m at free sight



8 Special Settings

For various sports and applications it can be necessary to change a setting of the Bang. First you have to switch off the Bang. Open the red marked screws.

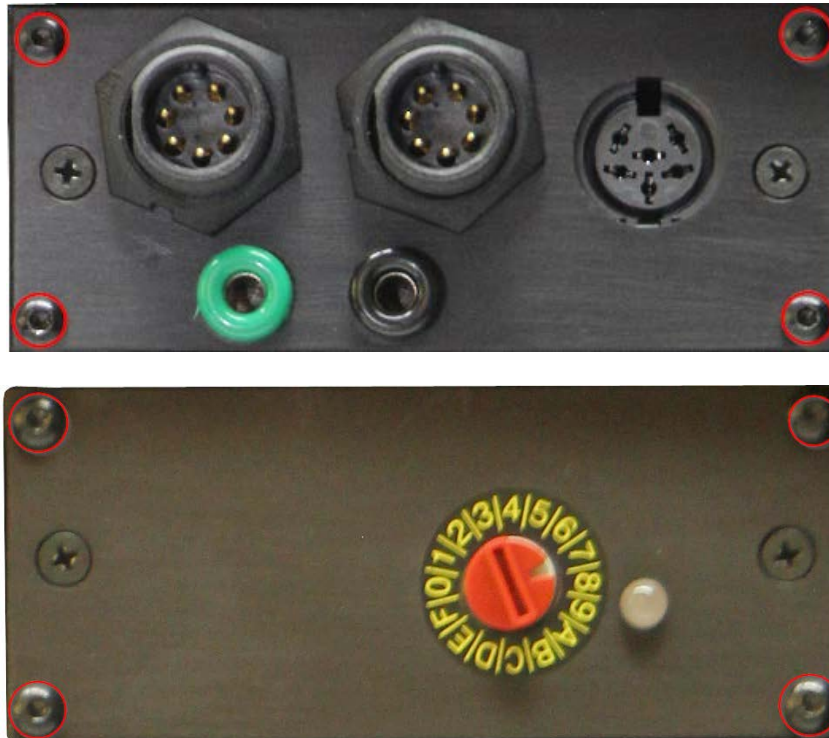

When the screws are removed, you can pull out the unit.

Now you can change the setting with the red jumper:

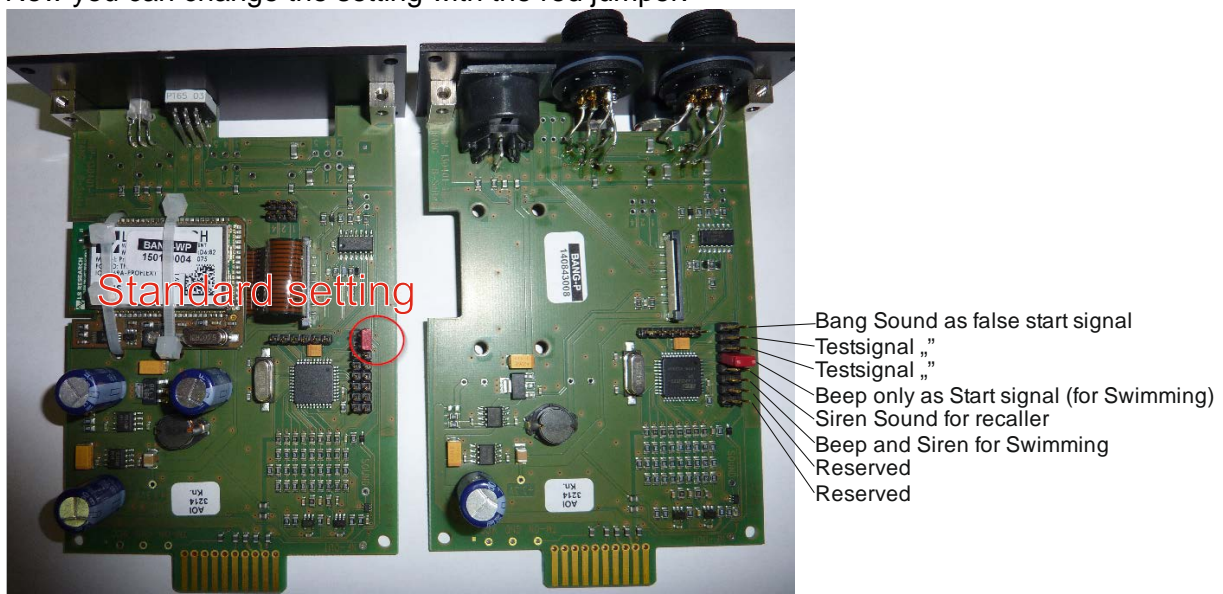

After finishing the setting plug the unit in the Bang again. After that you have to fix the screws again.

Hint:

The Settings „Beep as Start signal“ and „Siren Sound“ are available since March 2015.
The Settings „Beep and Siren for Swimming“ are available since May 2015.

Subject to changes

Copyright by

ALGE-TIMING GmbH

Rotkreuzstr. 39

6890 Lustenau / Austria

www.alge-timing.com